

Submittal Data Sheet

(H,Y)VWH(P,R)120B_2S Water Source Condensing Unit
10 Ton, Heat Pump and Heat Recovery, 208-230V/60/3 and 460V/60/3

Job Name:	Location:
Purchaser:	Order No:
Engineer:	
Submitted By:	Date:
Unit Designation:	Schedule No:
Construction:	Model No:



Features and Benefits

- Compact, modular and light weight equipment installed entirely inside the building enhances design flexibility and makes it easier to adapt to different building types
- Wide capacity range with all Inverter Compressors delivering maximum efficiency at part load conditions, providing comfortable individual zone control
- Outstanding VRF solution for cold climate applications – operation and capacity not affected by outside temperature, no defrost operation required
- Flexible solution with 1-, 4-, 8-, and 12- port change-over boxes for heat recovery applications
- Energy efficient and personal comfort solution via simultaneous cooling and heating capability, for heat recovery
- Refrigerant cooled Inverters for reliable and efficient operation
- Developed for easy installation and service – field selectable top or front refrigerant connections and easy accessible control and easy accessible control

Technical Data

(H,Y)VWHP120B_2S Heat Pump (H,Y)VWHR120B_2S Heat Recovery		
Unit Performance		
Product Number	(H,Y)VWH(P, R)120B32S	(H,Y)VWH(P, R)120B42S
Power Supply (V/Hz/Ph)	208-230/60/3	460/60/3
Nominal Capacity, Cooling (Btu/h)	120,000	
Nominal Capacity, Heating (Btu/h)	135,000	
IEER, Non-Ducted (Btu/wh)	26.10	
COP68, Non-Ducted, Heating (W/W)	4.95	
Unit Details		
MCA (A)	38-34	20
MOP (A)	60-50	30
Dimensions H x W x D (“)	39-3/8 x 30-11/16 x 21-5/8	
Net Weight (lbs)	381	390
Refr. Piping, Gas/HL(for HR)/Liquid (“)	7/8 / (3/4) / 1/2	
Water Pipe Size, Inlet and Outlet (“)	1-1/4	
Sound Pressure (dBA)	60	60
Refrigerant Type	R410A	
Refrigerant Charge (lbs)	10.4	
Water Inlet Temp Range (°F)	50-113	
Water Flow, Rated / Range (GPM)	25.4 / 20-56	
Pressure Drop at Rated Flow (ft wg)	13	
Max./Recommended No. of IUs	23 / 8	
Connection Ratio Range (%)	50 - 130	
System Details		
Max. Total Piping Length (ft)	984	
Max. Vert. Distance, CU above IU (ft)	164	
Max. Vert. Distance, CU below IU (ft)	131	
Max. Vertical Distance, IU to IU (ft)	49	

Performance ratings are based on AHRI 1230 test standard

For additional product information, refer to the Engineering Manual

Version 201810

Module Dimensions

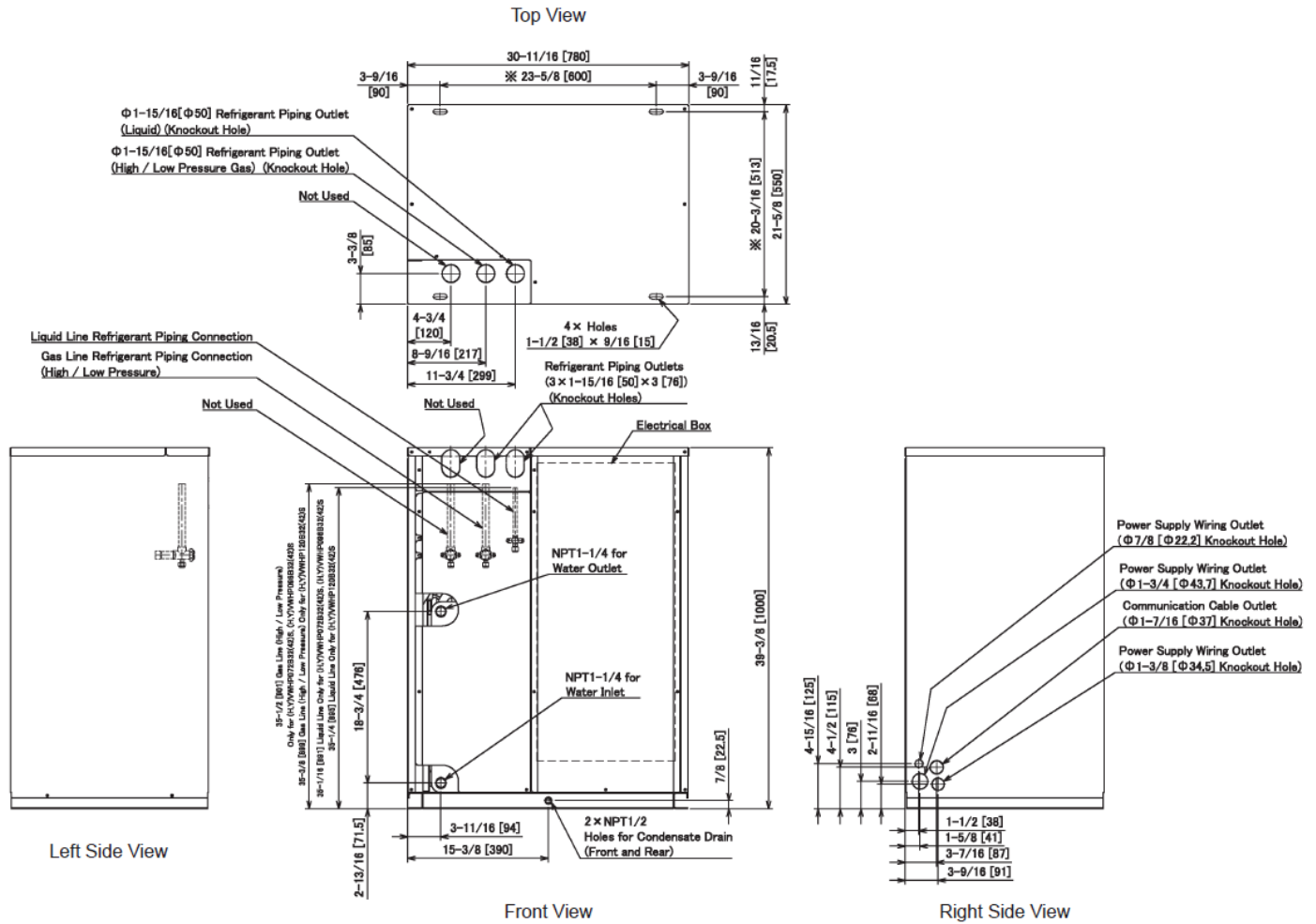

* 3rd pipe is for heat recovery only.

Piping Connections

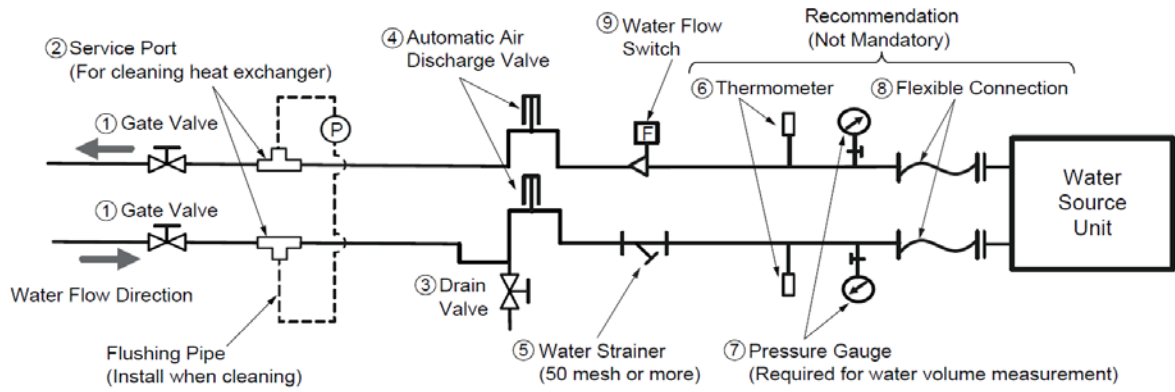

Items ① through ⑨ are field supplied.

Version 201810

